

Manual Multi Filter Control Valve

Product Technical Parameters

Model	Inlet/Outlet	Drain	Brine	Base	Flow Rate (m ³ /h)	Tank Size
F64A1	1" Female	1/2" Male	3/8" Male	2.5" Male	4.5	6" – 12"
F63B1	1" Female	1/2" Male	3/8" Male	2.5" Male	6	6" – 14"
N74A1	2" Female	1" Male	1/2" Male	4" Male	10	10" – 24"

Service Condition

Item	Requirements	
Service Conditions	Pressure	0.15 MPa – 0.6 MPa
	Temperature	5°C – 50°C
Inlet Water Quality	Turbidity	< 2 FTU
	Hardness	< 10 mmol/L
	Free Chlorine	< 0.1 mg/L
	Iron (Fe ²⁺)	< 0.3 mg/L
Application	Filter media	Ion Exchange Resin

System Configuration

Tank Size (inch)	Resin Volume (L)	Flow Rate (m ³ /hrs)	Brine Tank Size (mm)	Min. Salt for Regeneration (kg)
7x35	16	0.5	Dia 200 x H 500	2.4
8x35	25	0.7	Dia 250 x H 520	4.0
10x35	40	1.2	Dia 250 x H 520	6.0
10x54	60	1.8	Dia 400 x H 800	9.0
12x65	100	2.5	Dia 450 x H 940	15.0
14x65	150	4.5	Dia 550 x H 1160	22.5
16x72	200	5.0	Dia 740 x H 1250	30.0
20x72	300	7.0	Dia 840 x H 1400	45.0

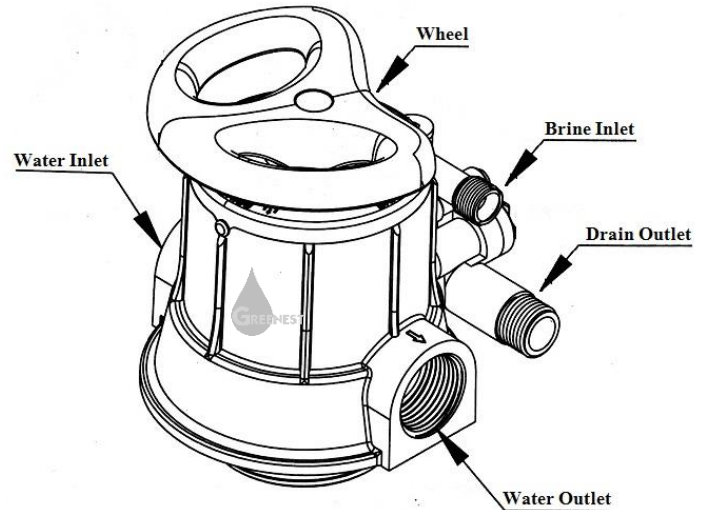

Working Principle

State	Action	Description	Flow Direction
State 1	Back Wash	Flushing dust, turbidity and other contaminants ,(15-20 min)	Water Inlet > Drain Outlet
State 2	Brine & Slow Rinse	Brine : Start to regenerate by salt (NaCl) (25 – 30 min)	Brine Line > Drain Outlet
		Slow rinse : arrange and cleaning media filter (25 – 30 min)	Water Inlet > Drain Outlet
State 3	Brine Refill	Feed water to brine tank for preparation to regenerate next time and the system continue in the fast rinse at the same time	Water Inlet > Brine Line and Drain Outlet
State 4	Fast Rinse	Cleaning media filter for preparation to State 4 (15 – 20 min)	Water Inlet > Drain Outlet
State 5	Service	The filter cycle is normal*	Water inlet > Water outlet

* Testing by Hardness tester before service on state 5

Manual Multi Filter Control Valve

Working Flow Chart

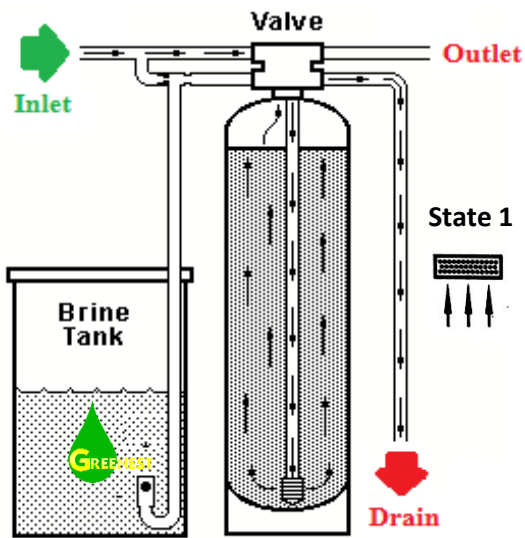

Back Wash

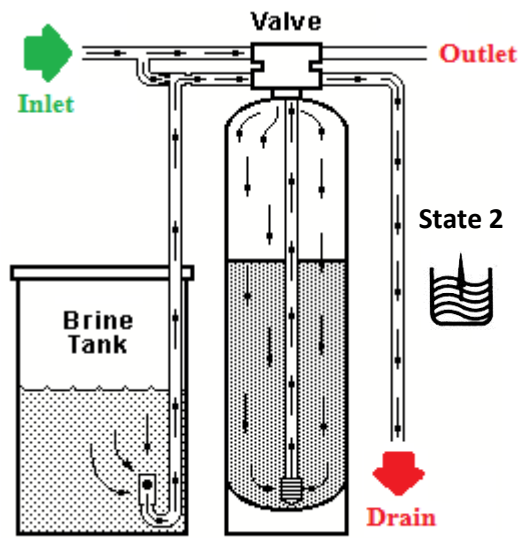

Brin

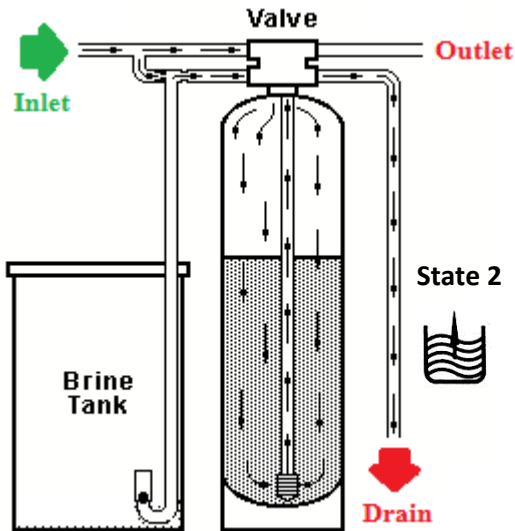

Slow Rinse

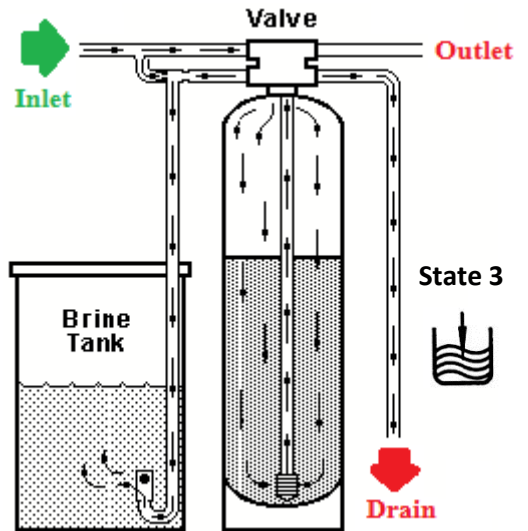

Brine Refill

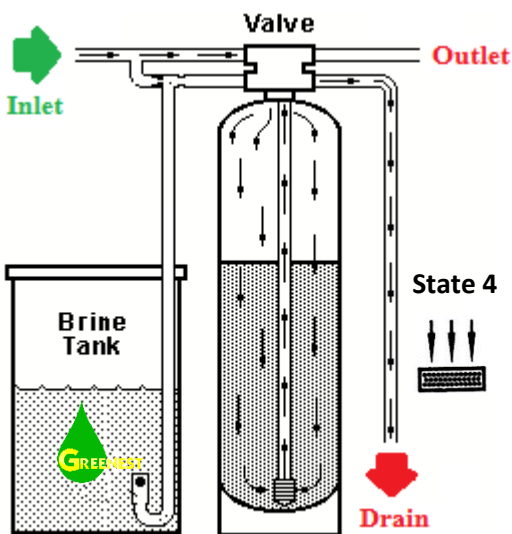

Fast Rinse

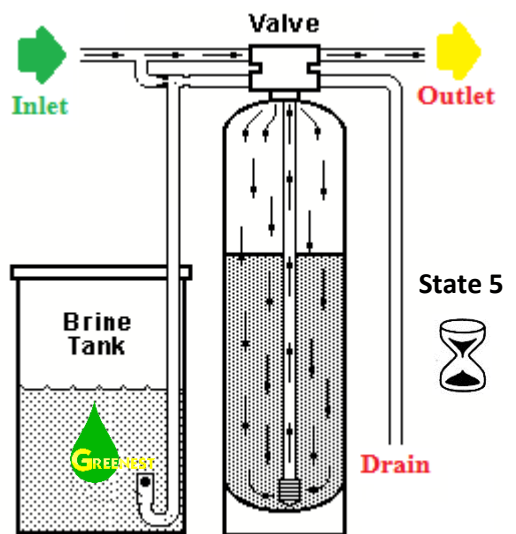

Service